

Examination of the Implementation and Utilization of Optical Fibers Beams: A Review

Mazullah Karimi

Department of Physic, Education Faculty, Faryab University, Faryab, AFGHANISTAN

Corresponding Author: mazullah1369@gmail.com

ABSTRACT

For light propagation purposes, the optical fibers that are known as waveguides can be applied. A glass or plastic film called cladding covers the central portion of the optical fiber, and is distinguished by a refractive index that is lower relative to the main refractive index. For the fine confines of the light inside the waveguide, the overall internal reflection phenomena are necessary. It is possible to categorize optical fibers according to shape, number of modes, refractive index profile, dispersion, signal processing power, and polarization. We are concentrating on the first three typical forms of optical fibers in this article. This may be used in fiber beams as a typical application of fibers to generate and intensify a small, powerful beam of coherent and monochromatic light. Optical fiber processing requires three steps, such as the development of performs. The process of adjusted chemical vapor deposition (MCVD) is a recognized technique that can be used to manufacture optical fibers. Optical fiber sensors are well known in optics and photonics for their large variety of applications. Optical biosensors can be developed as a sensing application focused on refractive index changes that are commonly utilized for the identification of biomolecules in their natural forms.

Keywords- MCVD, Coherent and Monochromatic Light, Refractive Index, Optical Fibers, Dispersion.

I. INTRODUCTION

In daily lives, light plays an important part. Light is used for data transfer in optoelectronics and optical fiber telecommunications, from compact disk players to laser printers and digital cameras, where a laser bouncing off a CD turns the return signal into audio. It facilitates optical fiber cables to link computers and telephone lines to each other. It has been used in many fields, including optical fiber beams, optical fiber interferometers, sensors and optical fiber modulators. In medicine, illumination is used to create images used in hospitals and beams that conduct eye surgery. Light extends across a much wider range than can be observed from the human eye. Electromagnetic radiation ranges from 850 nm, 1310 nm, and 1550 nm in many systems, such as optical fiber communication, where it is considered the near-infrared range.

Light comprises, basically, of a sequence of electromagnetic waves with light-particle properties. When light is called an atom, it refers to a photon stream that passes from one point to another. Photons are

identical to electrons and may be characterized as primary light particles. As light is added to the propagation of optical fibers, the light's object origin is of less concern due to its wave nature. Light is generally known to embody a dual existence. The electromagnetic range comprises of electromagnetic waves with frequencies of less than one hertz to more than 10^{25} Hz, equivalent to wavelengths of thousands of kilometers down to the scale of the atomic nucleus. Therefore, many distinct bands are used in the electromagnetic frequency spectrum, where various electromagnetic waves are known by different names in each frequency band, such as radio waves, microwaves, infrared, visible light, ultraviolet, X-rays starting from low frequencies (longer wavelengths) to high frequencies (shorter wavelength). Fig. 1 displays the electromagnetic range that helps one to locate the radiation involved in the propagation of optical fibers. Light is electric energy that is part of the electromagnetic spectrum. Light relates to the visible range of the electromagnetic spectrum visible to the human eye. In the visual spectrum, the wavelengths used are from 400-700 nm (nanometers) between the infrared and ultraviolet frequency bands. For the visible range, the related frequency range is 430-750 THz (terahertz).

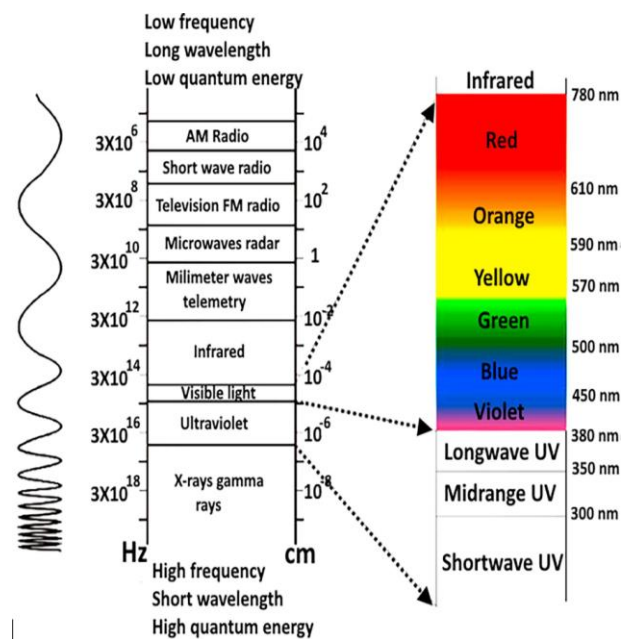

Figure 1: Nuclear range is found in the electromagnetic spectrum of spectrum bands.

The optical fibers are wave-guides that are used to relay light. There are three most significant optical fiber elements, such as the heart normally prepared from

II. OPERATIONAL THEORY

Optical fibers work on the basis of the absolute internal reflection phenomenon concept that exists at the interface between the core and the cladding, provided that the angle inside the heart of the incident light is greater than the angle considered the essential angle. The

the glass. A glass or plastic coating called cladding, which is distinguished by a lower refractive index relative to the raw content, covers the core.

incident light is then mirrored back through the center and propagates through the filament. When, at an angle greater than the critical angle, the light reaches the interface, it can not move into the other medium. The transmitted light at the interface is proportional to the incidence angle as well as the center and cladding refractive indices. The cumulative internal phenomenon of reflection are seen in Fig. 2.

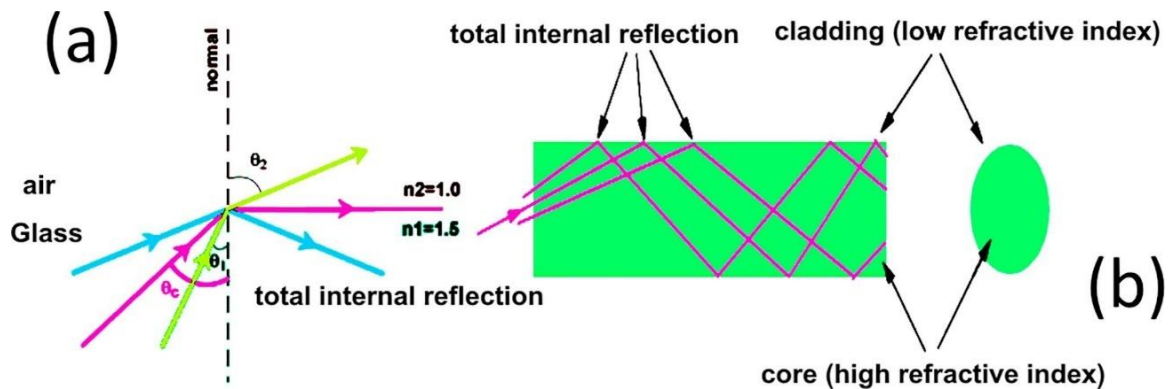

Figure 2: Absolute internal reflection, (a) in the mediums of glass and air, (b) in the structure of fiber with two mediums of glass having separate refractive indices.

As one can see from Fig. 2 (a), which is an intermediary between two mediums with separate indices of refraction, such as glass and air? If the angle of incidence I is less than the vital angle (c) , the light will travel through the air medium and it will be refracted back through the same medium as glass if $> I > c$. Fig. 2(b) illustrates the same principle where the two glass mediums in the fiber structure have separate

refractive indices. The core portion with a higher refractive index will direct the light through the complete phenomenon of internal reflection, thus regulating the same principle as defined in Fig. 2 (a). Fibers, along with a security coding, typically have one heart and one cladding, from fig. 3. There are four sections of the optical fiber, including the heart, the cladding, the buffer and the jacket.

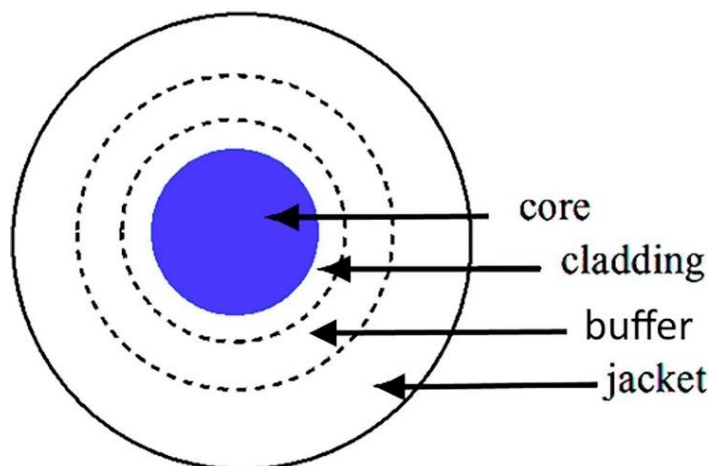

Figure 3: Optical fiber construction, with four parts such as heart, cladding, buffer, and jacket.

In general, the core segment has a cylindrical form made of dielectric material with a peculiar refractive index. The core portion is enclosed by the cladding part, which has a lower refractive index of glass or plastic than

the core section. A few tasks are carried out by the cladding portion, such as reducing the leakage of light from the heart to the ambient air. As a plastic buffer, the cladding portion is surrounded by an external elastic

coating that prevents the optical fiber from physical harm and dispersion losses induced by micro bending. The last layer is the layer of the jacket that can be used to identify the shape of the fibre. Because of its purity, most fibers are produced out of quartz glass. Due to their capacity to communicate at speeds above 10 GB per second, optical fibers are typically used in invoice processing, data transmission, and photonics. In the fields of optoelectronics, cameras, micromachines, fine metals, ceramic powders and defensive coatings, these applications can be identified. Optical fibers are commonly used in optical fiber networking, allowing for communication over greater distances and at higher speeds than wired and cellular networks that utilize materials other than optical fibers.

III. OPTICAL FIBER TYPES

It is essential to research their characteristic forms in order to understand the applications of optical fibers. In general, optical fibers can be categorized on the basis of the following aspects: (i) Structure: it can be cylindrical, birefringent, planar or strip, (ii) Number of modes: multi-mode and single-mode, (iii) Refractive index profile: step-index and gradient-index fibers, (iv) Dispersion: (iv) Dispersion: multi-mode and single-mode, (v) Dispersion: The first three typical forms of optical fibers, which are listed as follows, are discussed in this article.

Based on the frameworks presented in the following information:

a) Cylindrical optical fiber

This consists of the heart, which is normally glass through which light passes. A cylindrical sheet of material which has a lower refractive index is often enclosed by this center and is classified as cladding. The divergence in the refractive index is 0.005. Protecting the core is the function of the jacket .

b) Planar waveguide fiber

The rectangular block comprising three layers as the foundation, light guidance and coating is made of this form of fiber. The refractive index of the base and the coating index are lower than those of the other layers.

Centered upon the amount of the mode:

a. Multi-mode fiber

For short distance communications such as local area network networks and video monitoring, this form of fiber is applicable . It has an extremely large 50-62.5 μm core diameter. In random mode, the broad diameter of the heart forces the impulse to travel through various optical paths, so the rays shift at different intervals to contact the detector. It allows the signal to be momentarily extended, hindering the speed of data transmission and the effective distance of transmission to around 200-500 m.

b. Single-mode fiber

On the other side, single-mode fibers are best used for greater contact lengths, and are ideal for both long-distance telecommunications and multi-channel

television transmitting networks. There are limited core diameters of 5 to 10 μm for single-mode fibers. In the multi-mode and single-mode fibers, the cladding diameter is 125 μm , as seen in Fig. 4.

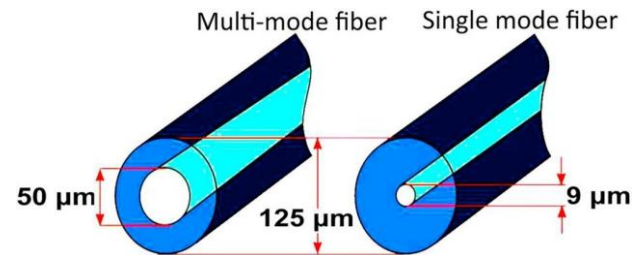

Figure 4: Single-mode and multi-mode material, single-mode and multi-mode fiber measurements have core diameters of 9 μm and 50 μm respectively, with a cladding diameter of 125 μm respectively.

The light propagation takes place on the axis parallel to that of the fiber owing to the limited size of the center diameter of single-mode fibers. In single-mode fibers, though, light transmission is only feasible if a certain requirement such as $v < 2.405$ is met. V is a normalized frequency, and the following equation can be defined.

$$v = \frac{2\pi a}{\lambda_0} \sqrt{n_1^2 - n_2^2}$$

Where, a is the central diameter of the fiber, λ_0 is the wavelength of light propagation, n_1 is the core refractive index and n_2 is the cladding refractive index. The optical fiber acts as a multiple-mode fiber when the normalized frequency is high. There is a shortage of intermodal dispersion in single-mode fibers, so the light signal hits the end of the fiber with a minor blur.

Based on the profile of the refractive indices

It is possible to also distinguish fibers depending on the refractive index profile. Fibers are divided into fibers of the phase and gradient index here. At the interface between the cladding and the core, the step-index and gradient index fibers have a core that is constant and the refractive index discontinuous. The RI of the core is stronger at the middle of the core in the gradient index fiber and progressively falls as the interface reaches.

Fiber Repair Polarization

For many applications, such as fiber interferometers, fiber beams, sensors, external fiber modulators, integrated optical circuit coupling and coherent light transmission, the maintenance of constant light polarisation is necessary. The fiber maintenance polarization is built to transmit just one polarization of the input light. It consists of a characteristic that in another type of fiber can not be seen. Two circles called stress rods are present in addition to the heart, which produce stress in the fiber core in which only one polarization is preferred for transmission.

While light may be sent down a fiber, there are several variables that come into play, including fiber form, core size, numerical aperture, refractive index, and doping, such as the variables that influence light transmission through the fiber. These factors relate to the expansion of the spectrum of light communications applications. We are, though, aiming for single-mode fibers, where it is impossible to send light down a single-mode fiber as the light source is costly. How should we find a balance between power, growth, and the economy? It was discovered by experiments that adjusting the refractive index regularly along the length of an optical fiber might cause light reflections. This produces a grating to build a form of mirror that takes advantage of the rule of Bragg.

Fiber laser

The fiber laser may be based on either the Erbium-Doped Fiber Amplification (EDFA) or the Ytterbium-Doped Fiber Amplifier (YDFA). A laser is a system that produces a small, powerful beam of coherent, monochromatic light and amplifies it. A fiber laser operates by reflecting light into an optical cavity, such that atoms that accumulate and emit light energy at varying wavelengths are activated by a stream of photons. There are two separate conditions with an atom as ground

and excited states. The condition of the ground has the lowest energy and is the most secure state. In a laser, the atoms are stimulated in the cavity of the laser such that the higher energy levels will find more of them. A certain wavelength photon activates and triggers other electrons to produce more photons that are in transition as an activated electron slips down into a lower energy range. The most famous lasing atoms are these elements that originated in the lanthanide sequence Ytterbium (70Yb) on the periodic table. The fiber core can therefore be doped in order to control the refractive index and the absorption of photons. The Yb has an absorption curve, literally, like the one seen in Fig. 5 with the cross-section of the center of the Ytterbium-doped germanosilicate glass fiber compared to the wavelength (nm). Only in Fig. 5, the range of emission and absorption was presented. The pumping can be applied at wavelengths about 910 nm to around 975 nm, where the excitation frequency of just 50 percent can be reached for the 975 nm pumping induced by the stimulated emission, where the absorption duration and the quantum defect are lower relative to that for the 910 nm pumping. The efficient and almost three and four-level behaviors occur with very low reabsorption for lasing about 1030 nm and behind 1080 nm, respectively.

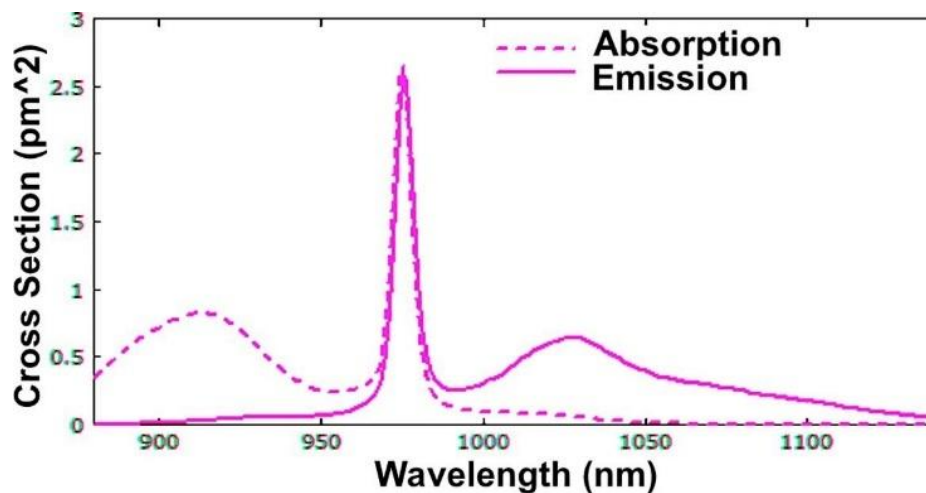

Figure 5: The cross-section of the core versus the wavelength is the ytterbium-doped German silicate glass used in the core of the fibre (nm).

At a shorter wavelength of 910 nm, a larger light range can be absorbed, while at a wavelength of 975 nm, a more effective absorption exists. As proof of the consumed radiation, a process called pumping, the photon absorbed by the Yb dopant escapes and the electron travels into the higher orbital inside the atomic nucleus. Other elements such as erbium, neodymium, praseodymium, dysprosium, thulium, and holmium are also used for optical fiber doping.

A ring structure may be presumed for each EDFA or YDFA laser cavity, where it is made entirely of isotropic single-mode fiber. The Yb and Er fiber amplifiers used consist of single-mode active fiber Yb-

doped and single-mode active fiber Er-doped, respectively, where a 974 nm laser diode is co-pumped, as shown in Fig. 6. For pumping the EDF/YDF into a wavelength division multiplexer, a 974 nm laser diode is used (WDM). The majority of the cavity is made up of single-mode thread. To ensure unidirectional transmission, a polarization-independent optical isolator is used, where the polarization controller (PC) is used to change the birefringence of the net cavity. The integration into the laser cavity of the material saturable absorber (SA) enables Q-switched or mode-locked production of pulses by passive techniques.

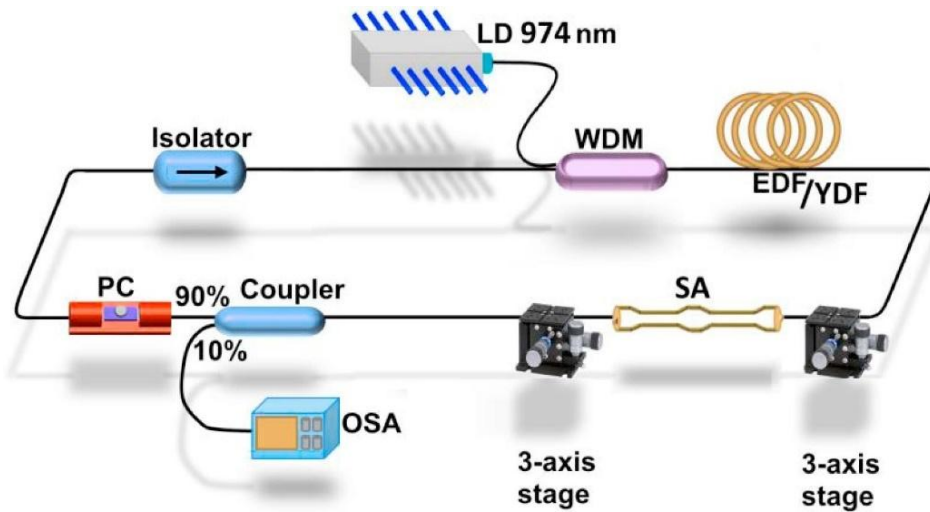

Figure 6: Polarization controller (PC), Isolator (ISO), Saturable absorber (SA), Optical spectrum analyzer, Wavelength Division Multiplexer (WDM) (OSA).

Fabricating optical fibre

Fabrication of optical fiber (shown in Fig. 7) involves three stages as follow. The perform formation, a glass cylinder that could be used to prepare the optical fiber. This possesses a length of 3 feet with a width of 1 in.. Its physical look is similar to that of the finished fiber possessing core and cladding that is much wider and shorter. This is followed by the pulling stage where the heating of the perform takes place at a temperature of about 2000 °C followed by pulling off a tiny strand of glass at one end. It is necessary to control the diameter of

the strand carefully, through adjustments in heating and also the tension applied during the pulling process. This strand becomes the optical fiber consisting of both core and cladding. Finally, the fiber is cooled slowly and carefully, covered with a jacket and coiled reels. There are three most important approaches to fabricate fibers with moderate low loss waveguide .These are (1) The modified chemical vapor deposition method or MCVD, (2) The outside vapor deposition method or OVD, and (3) Vapour axial deposition method or VAD.

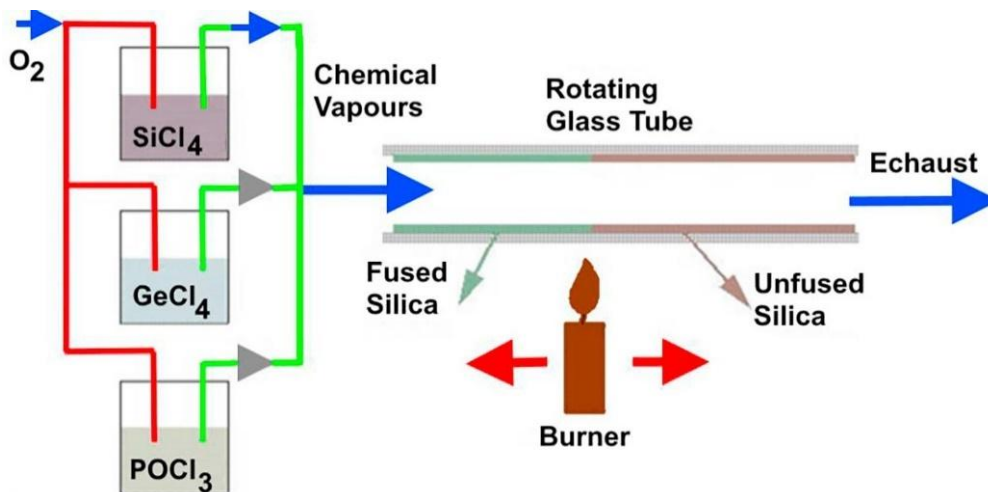

Figure 7: The changed precipitation of chemical vapors.

IV. CONCLUSION

In several fields of telecommunications, photonics, medical and infrastructure, optical fiber technology has been used. Because of its efficiency, low loss, no interruption, greater bandwidth and its inherently strong data-carrying power, it has attracted many researchers. While there are several benefits of optical

fibers, there are also certain pitfalls associated with optical fiber technology. One of the drawbacks of optical fibers is that the fibers are more costly relative to copper cables, considering the inherent availability of the substrate for optical fiber construction that is the sand. Another downside is that for optical fiber mounting, highly trained manpower is needed.

REFERENCES

- [1] Shekaramiz M, Moon TK, Gunther JH. AMP-B-SBL: an algorithm for clustered sparse signals using approximate message passing, Ubiquitous Computing, Electronics & Mobile Communication Conference (UEMCON), IEEE Annual, NIH Public Access, 2016.
- [2] M. Shekaramiz, T.K. Moon, J.H. Gunther On the block-sparsity of multiple-measurement vectors 2015 IEEE Signal Processing and Signal Processing Education Workshop (SP/SPE), IEEE (2015), pp. 220-225
- [3] A.E. Willner, S. Khaleghi, M.R. Chitgarha, O.F. Yilmaz All-optical signal processing J Lightwave Technol, 32 (2014), pp. 660-680
- [4] P.J. Winzer Scaling optical fiber networks: challenges and solutions Opt Photonics News, 26 (2015), pp. 28-35
- [5] T. Müller, J. Skibazymanska, A. Krysa, J. Huwer, M. Felle, M. Anderson, *et al.* A quantum light-emitting diode for the standard telecom window around 1550 nm Nature Commun., 9 (2018), p. 862
- [6] M. Hernaez, C.R. Zamarreño, S. Melendi-Espina, L.R. Bird, A.G. Mayes, F.J. Arregui Optical fibre sensors using graphene-based materials: a review Sensors, 17 (2017), p. 155
- [7] K. Moghissi, K. Dixon, Image-guided surgery and therapy for lung cancer: a critical review, Future Oncol, 13 (2017), pp. 2383-2394
- [8] P. Lodahl, S. Mahmoodian, S. Stobbe, A. Rausche nbetel, P. Schneeweiss, J. Volz, *et al.* Chiral quantum optics
- [9] M.L. Ámundadóttir, S.W. Lockley, M. Andersen- Unified framework to evaluate non-visual spectral effectiveness of light for human health
- [10] R. Di Sante- Fibre optic sensors for structural health monitoring of aircraft composite structures: recent advances and applications, Sensors, 15 (2015), pp. 18666-18713
- [11] S. Personick- Review of fundamentals of optical fiber systems, IEEE J Sel Areas Commun, 1 (1983), pp. 373-380
- [12] V. Kouhdaragh, D. Tarchi, A. Vanelli-Coralli, G.E. Corazza, Smart Grid Inspired Future Technologies, Springer, 24 (2017), p. 16